

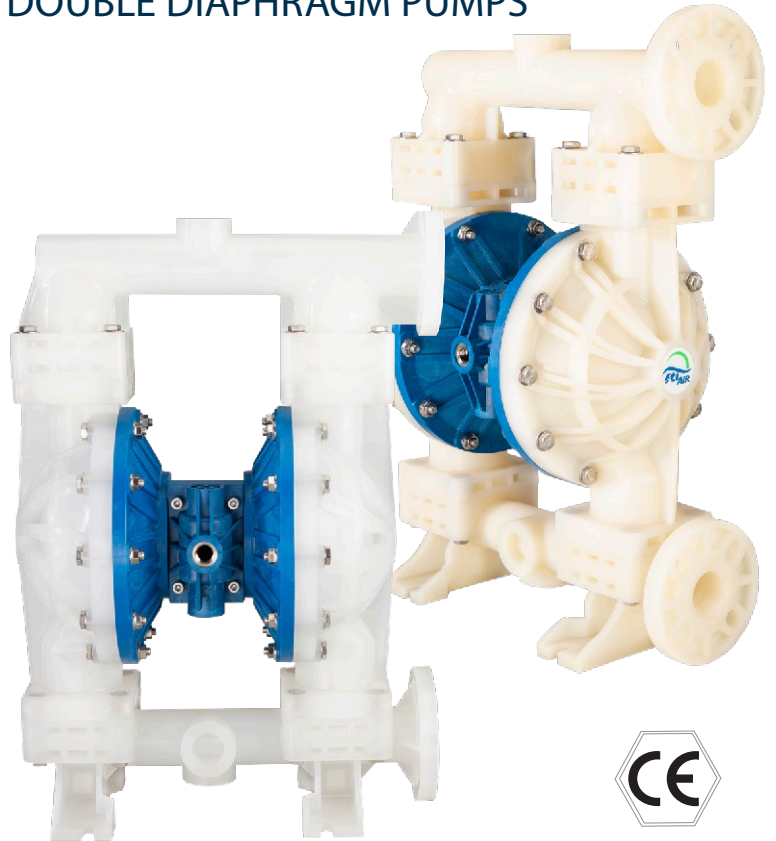

Model FT15Z Non-Metallic

AIR OPERATED DOUBLE DIAPHRAGM PUMPS



Specifications

Suction & Discharge Size:	1.5" x 1.5"
Porting Location*:	End
Connection Types:	ANSI/DIN/ISO Flange w/ FNPT or FBSPT Threads
Air Inlet & Air Exhaust Size:	1/2" FNPT x 3/4" FNPT

*Optional NPT or BSP threaded center port location in either horizontal or vertical position

Capabilities

Maximum Flow Rate:	125 gpm (473 lpm)
Maximum Air Supply Pressure:	100 psig (6.9 bar)
Displacement Per Stroke:	0.24 gal (0.91 lit)
Minimum Air Inlet Pressure:	10 psig (0.7 bar)
Maximum Particle Size :	0.32 in (8.2 mm)
Sound Pressure:	77 dB(A)
Operating temperature:	Determined by elastomers

FT15Z Performance

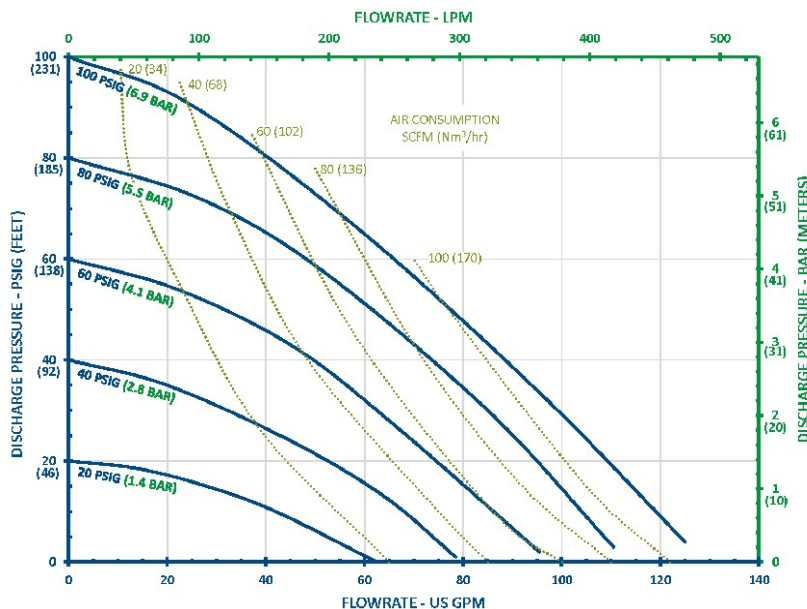

Note: Full stroke diaphragm allows performance to be equal for all elastomers.

Typical Applications

- Acids & Bases
- Plating Solutions
- Wastewater
- Paints, Inks, Solvents
- Ceramic Slip and Glaze
- Lubricants and Oils

Typical Industries

- Mining
- Paints and Coatings
- Ceramics
- Pulp and Paper
- Electroplating & Anodizing
- Wastewater
- Marine
- Chemical Manufacturing & Distribution
- OEM's

Construction

Wetted Materials:	Polypropylene, PVDF
Diaphragm Materials:	Neoprene, Santoprene™, FKM, EPDM, PTFE, Buna, Hytrel®, Polyurethane
Air Valve:	GFRPP, Aluminum
Ball Materials:	Neoprene, Buna, EPDM, FKM, Santoprene™, PTFE, 316SS
Seat Materials:	Polypropylene, PVDF, Aluminum, 316SS, PTFE, Neoprene, Buna, EPDM, FKM, Santoprene™, Hytrel®, Polyurethane
O-ring Materials:	Buna, FKM, Santoprene™, Polyurethane, FEP/FKM, Neoprene, EPDM

Santoprene™ is a registered trademark of Exxon Mobil Corp.
 Hytrel® is a registered trademark of Dupont™
 Pat. <http://ftiair.com/resources/ip/>

CHANGE IS IN THE AIR

Dimensions

Maximum Height:	26-5/8 in (677 mm)
Maximum Width:	18-11/16 in (475 mm)
Maximum Depth:	11-13/32 in (290 mm)

Weight

Polypropylene:	41.0 lb (18.6 kg)
PVDF:	60.0 lb (27.2 kg)

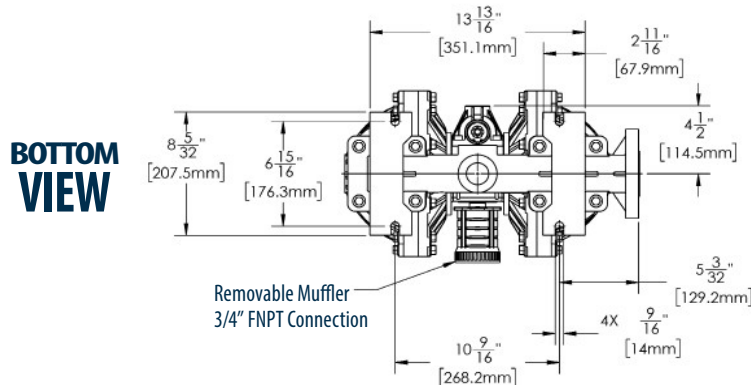
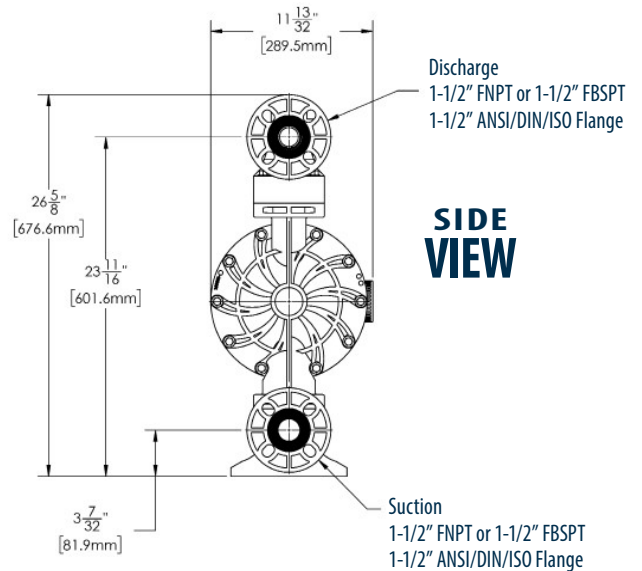
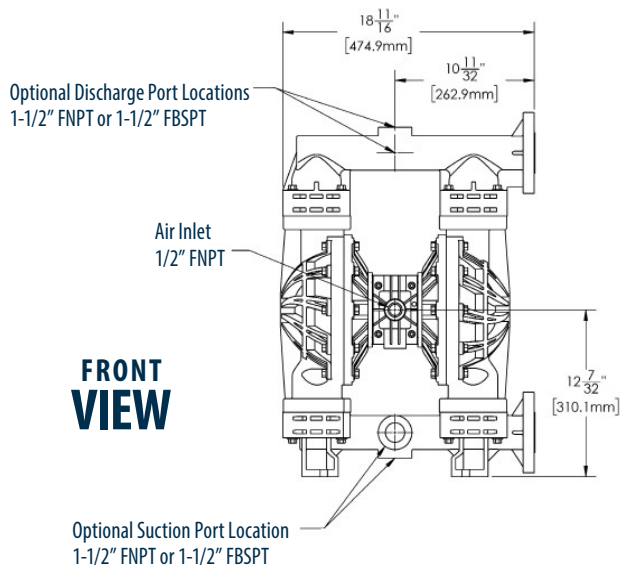

FTI AIR

921 GREENGARDEN ROAD ERIE, PA 16501
 Tel: (800) 934-9384 • Fax: (814) 459-3460
www.FTIAIR.com

